

OIL WATER SEPARATOR ALARM CONSOLE

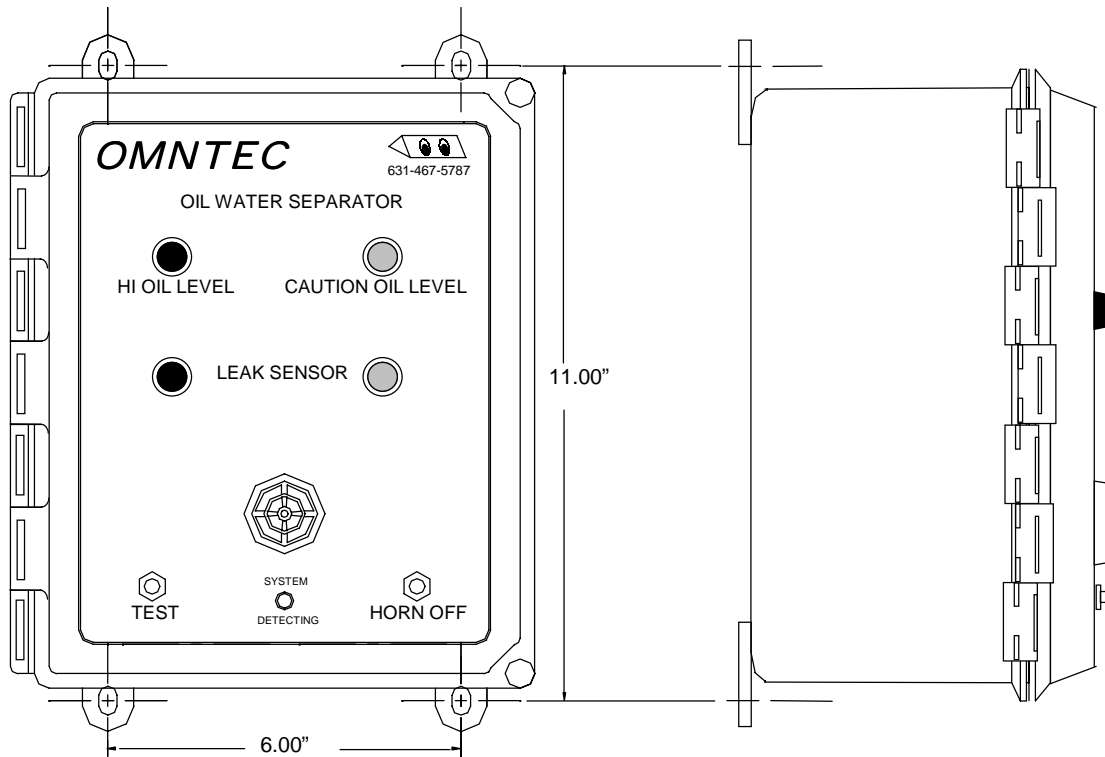

**SPECIFICATIONS**

**POWER INPUT**

85-125 VAC, 47-440 Hz  
16 Watts maximum

**POWER TO SENSORS**

13.80 VDC @ 13 ma maximum

**RELAY OUTPUT**

SPST normally open dry contacts 1.25 AMPS, 120 AC/DC switches when an alarm condition occurs

**WEIGHT**

6 LBS.

**ENCLOSURE**

NEMA 4X

**DIMENSIONS**

(W) 9" x (H) 10.5"

**SENSOR CABLE**

Shielded 22 AWG UL-E118830 CM  
Maximum length 2000 feet

**ENCLOSURE**

NEMA 4X

**OPERATING TEMPERATURE**

-40° to 140° F

**UL LISTED**

Intrinsically safe circuits for use in class I group D hazardous locations when connected in accordance with control drawing LU3OWIR

**LABELS**

Provided with controller

**AUDIO/VISUAL CONSOLE**

**AUDIBLE ALARM** - 95 dB pulsing horn with no timeout

**CAUTION OIL LIGHT** – indicates oil has accumulated below the caution oil interface float

**HI OIL LIGHT** -Indicates oil has accumulated below the hi oil interface float or the tank liquid level is below the hi oil interface float

**RED LEAK LIGHT** - indicates hi alarm for L-R-1 or product alarm for PD-series sensor

**AMBER LEAK LIGHT** – indicates low level alarm for L-R-1 or water alarm for PD-series sensor

**TEST BUTTON**- When pressed will test system electronics

**GREEN LIGHT**- indicates the power is on

**HORN OFF BUTTON** - Silences the audible alarm when pressed

**SENSORS**

OWI-2 Two point oil/water interface float sensor

L-R-1 – reservoir sensor

PD-series product distinguishing liquid optic sensor

**ACCESSORIES**

RA-1 audio/visual remote annunciator

RLY-RA Relay (consult factory)

RA-1-NYS Remote annunciator with strobe (consult factory)

# ELP21LU3-OWIR

## CONTROLLER CONNECTION DIAGRAM

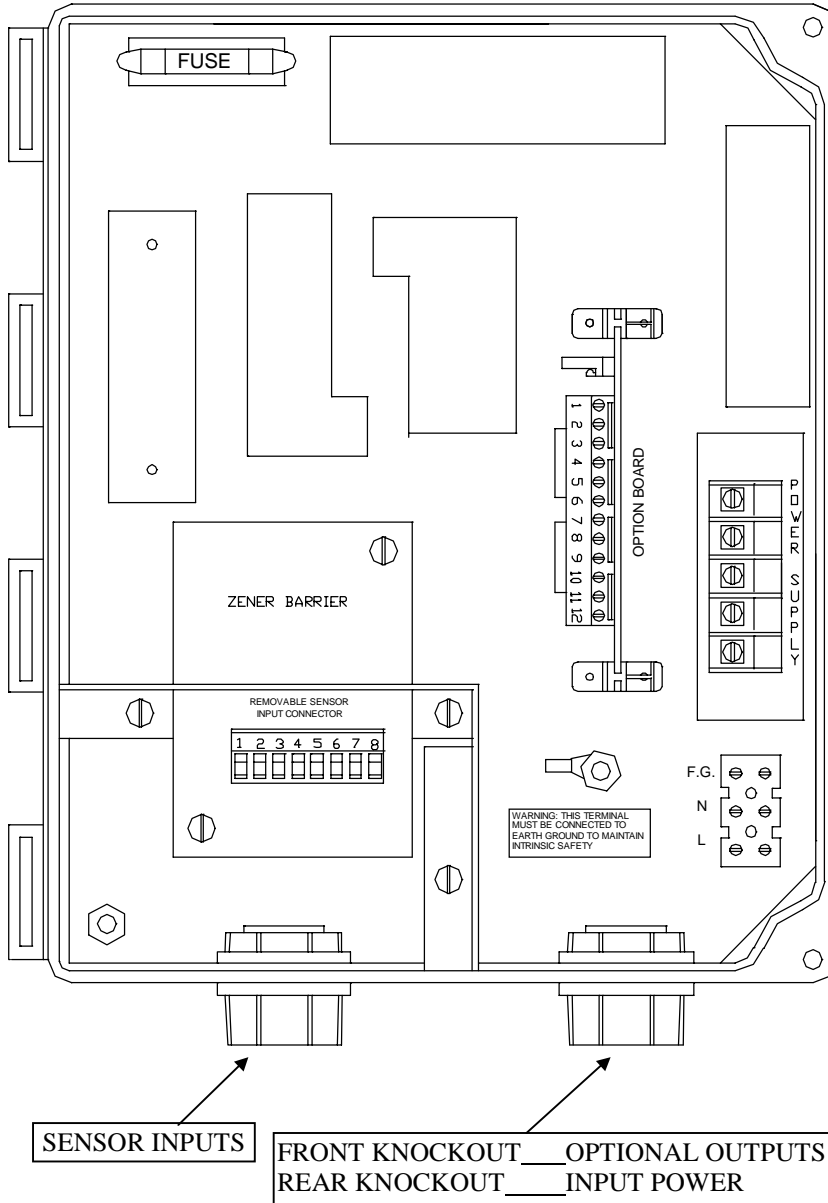

### COLOR CODE

#### CABLES FROM SENSORS TO REMOVABLE SENSOR INPUT CONNECTORS

|   |              |                     |                    |
|---|--------------|---------------------|--------------------|
| 1 | RED          | HI OIL LEVEL        | SENSOR #1<br>OWI-2 |
| 2 | WHITE        | CAUTION OIL LEVEL   |                    |
| 3 | UNUSED       |                     |                    |
| 4 | RED          | LEAK DETECTION      | SENSOR #2          |
| 5 | WHITE        |                     |                    |
| 6 | GREEN        |                     |                    |
| 7 | BLACK        | FROM SENSOR #1 & #2 |                    |
| 8 | SHIELD DRAIN | FROM SENSOR #1 & #2 |                    |

#### WIRES TO OPTION BOARD

#### WIRES FROM RA-SERIES REMOTE

|   |        |                   |
|---|--------|-------------------|
| 1 | GREEN  | -HORN             |
| 2 | RED    | +HORN             |
| 3 | BLACK  | GROUND            |
| 4 | WHITE  | HIGH OIL LEVEL    |
| 5 | ORANGE | CAUTION OIL LEVEL |
| 6 | BLUE   | LEAK DETECTION    |

#### WIRES FROM RELAY OUTPUTS

|    |               |                   |
|----|---------------|-------------------|
| 7  | COMMON        | LEAK DETECTION    |
| 8  | NORMALLY OPEN |                   |
| 9  | COMMON        | CAUTION OIL LEVEL |
| 10 | NORMALLY OPEN |                   |
| 11 | COMMON        | HIGH OIL LEVEL    |
| 12 | NORMALLY OPEN |                   |

### 120VAC

#### WIRES TO POWER SUPPLY

|      |              |
|------|--------------|
| F.G. | FIELD GROUND |
| L    | LINE         |
| N    | NEUTRAL      |

NOTE: To maintain proper shielding, BLACK sensor wires and SHIELD DRAINS should **not** be connected together at sensors.

# ELP21LU3-OWIR SYSTEM CONTROL DRAWING

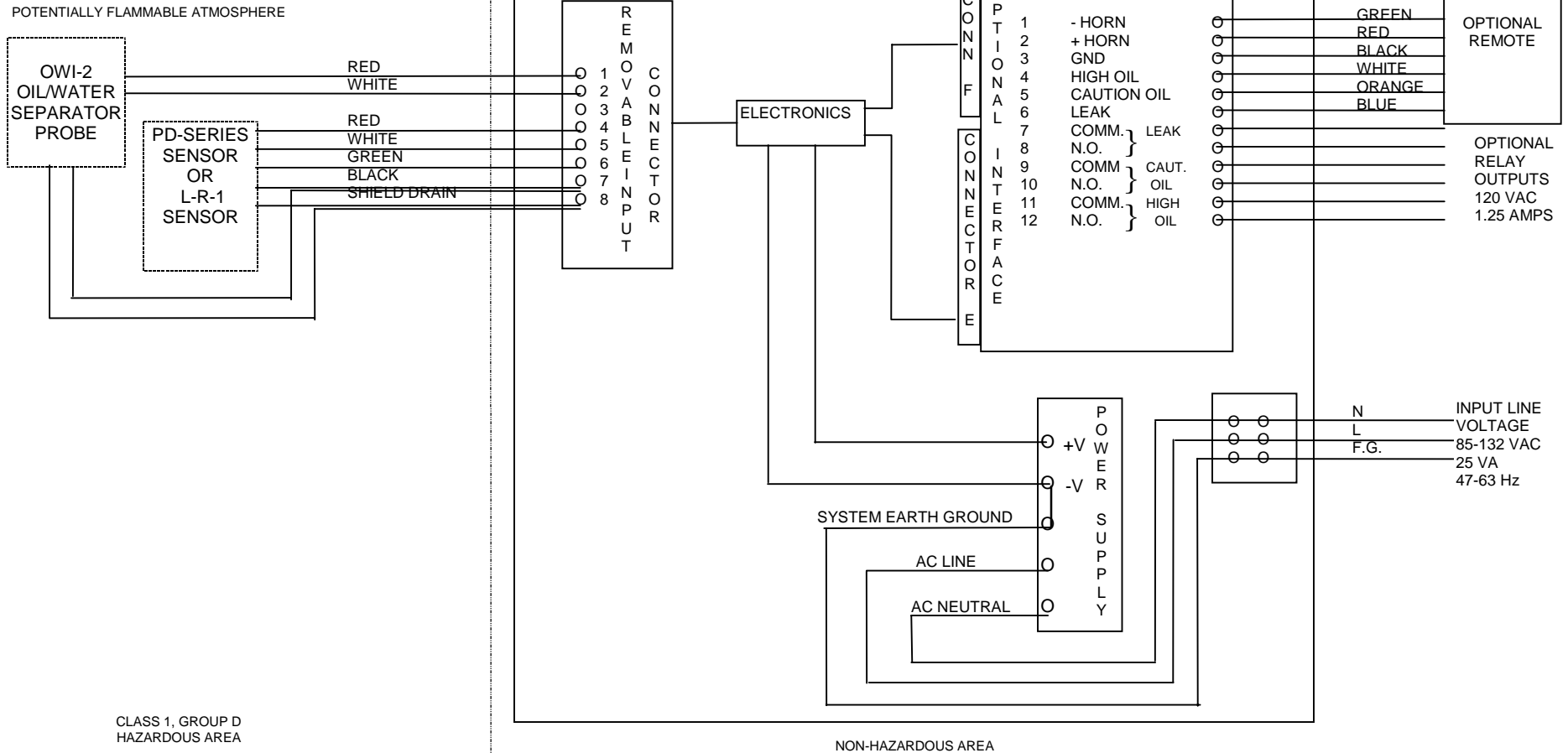

CLASS 1, GROUP D  
HAZARDOUS AREA

NON-HAZARDOUS AREA

## NOTES ON PROBES

1. THE INTRINSICALLY SAFE FIELD WIRING SHALL BE INSTALLED IN ACCORDANCE WITH ARTICLE 504 IN THE NATIONAL ELECTRICAL CODE ANSI/NFPA 70
2. ALL PROBES ARE ELECTRICALLY IDENTICAL AND MAY BE INTERCHANGED ALLOWING SYSTEM FLEXIBILITY
3. PROBE TO CONTROL UNIT CABLE WILL BE TWO PAIR OF #22 AWG WITH SHIELD AND DRAIN PVC JACKETED UL-118830 CM. CABLE LENGTH WILL BE LIMITED TO 2000 FEET MAXIMUM

## NOTES ON CONTROL EQUIPMENT

1. ALL WIRING MUST MEET LOCAL AND NATIONAL ELECTRICAL CODES
2. SYSTEM EARTH GROUND MUST BE CONNECTED TO TERMINAL F.G. TO INSURE INTRINSIC SAFETY AND MUST BE LESS THEN 1Ω WITH RESPECT TO EARTH GROUND
3. OPTIONAL REMOTE REQUIRES #22 AWG LOW VOLTAGE COMMUNICATION CABLE MINIMUM

# RA-Series Remote High Level Alarm

RA-1

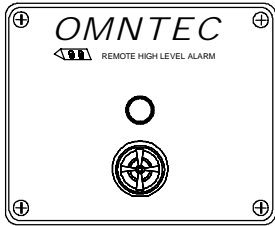

RA-2

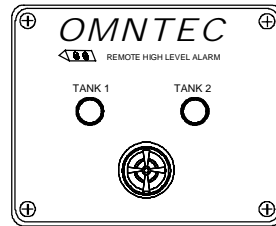

RA-3

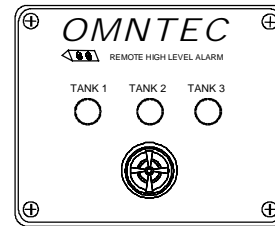

RA-4

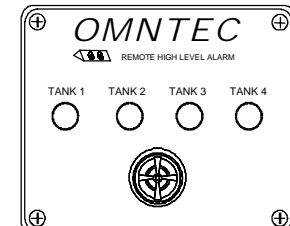

## INTERNAL WIRING COLOR CODE

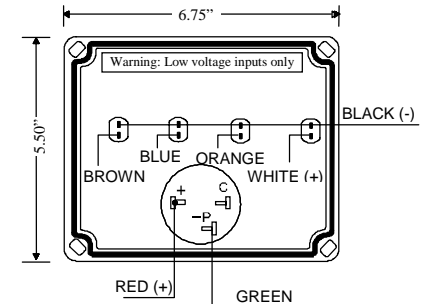
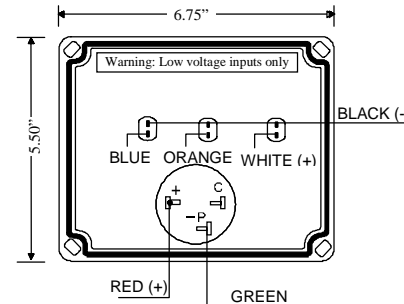
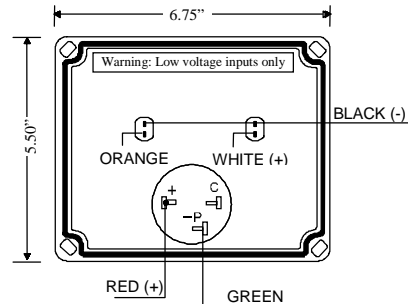
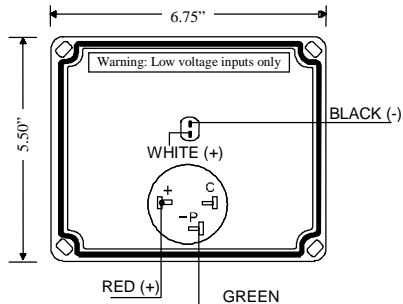

SIDE VIEW

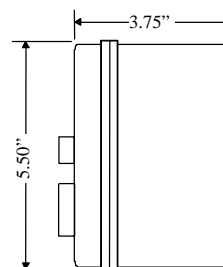

MOUNTING DIMENSIONS

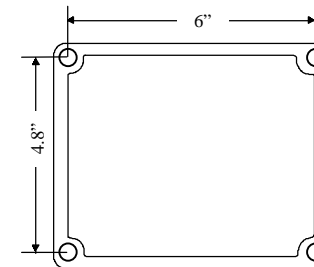

### SPECIFICATIONS

|               |   |
|---------------|---|
| Audible Alarm | 95 dB pulsing horn                      |
| Red Light     | Liquid-high-level alarm                 |
| Response Time | Immediate                               |
| Power Input   | 12VDC @200mA maximum<br>from controller |
| Wire          | 22 AWG minimum                          |
| Weight        | 1 lb.                                   |

Note:  
It is recommended  
that knockouts be  
placed in the  
bottom of the  
enclosure

# OWI-2 OIL WATER SEPARATOR

## TYPICAL MANWAY EXTENSION BRACKET INSTALLATION

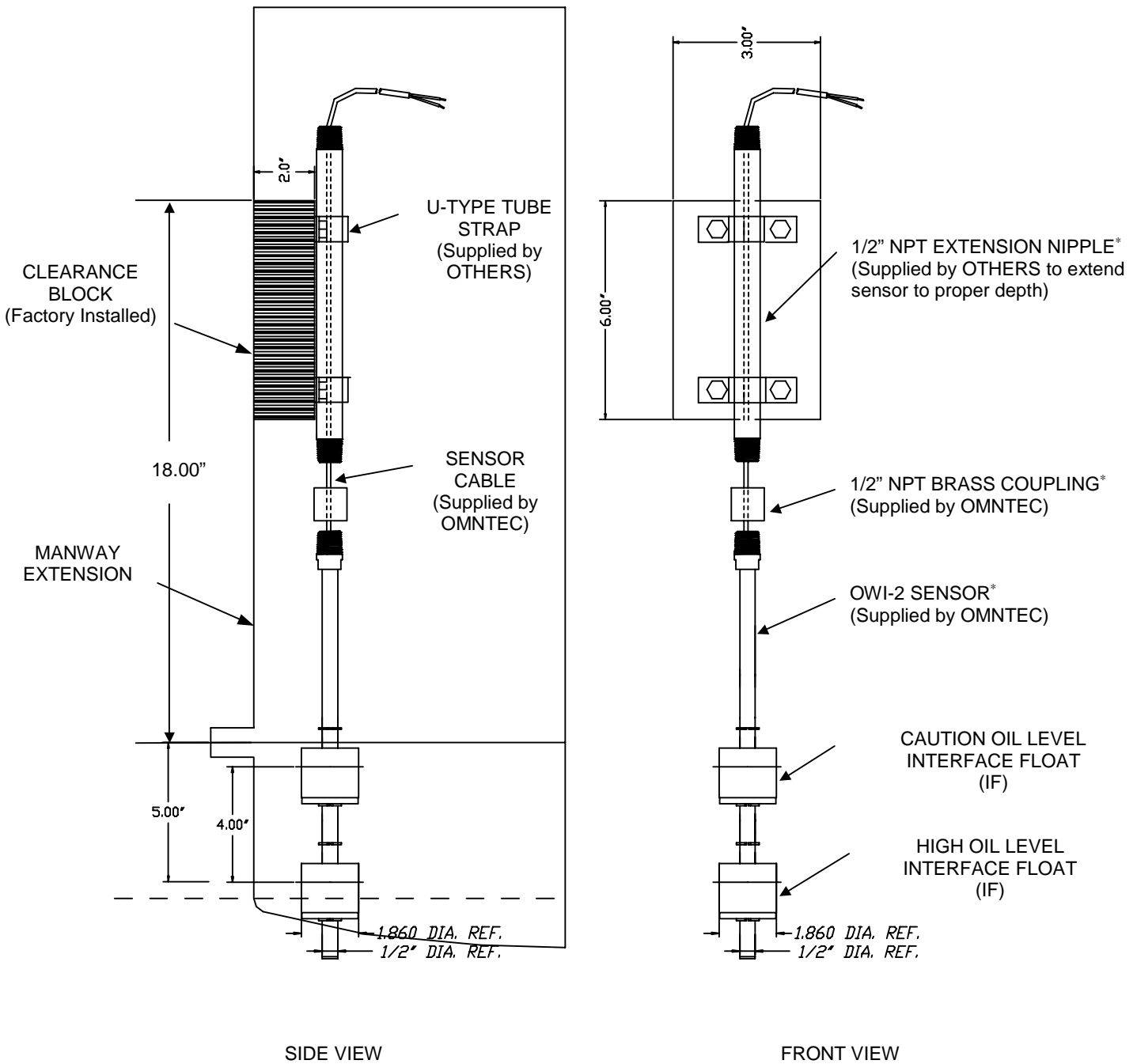

\* **WARNING-** It is the installer's responsibility to select a thread sealant that is compatible with the product being stored and that all NPT fittings are fastened properly to assure liquid tight seal for proper sensor operation.

# OWI-2 OIL WATER SEPARATOR

## TYPICAL 2" FITTING ASSEMBLY

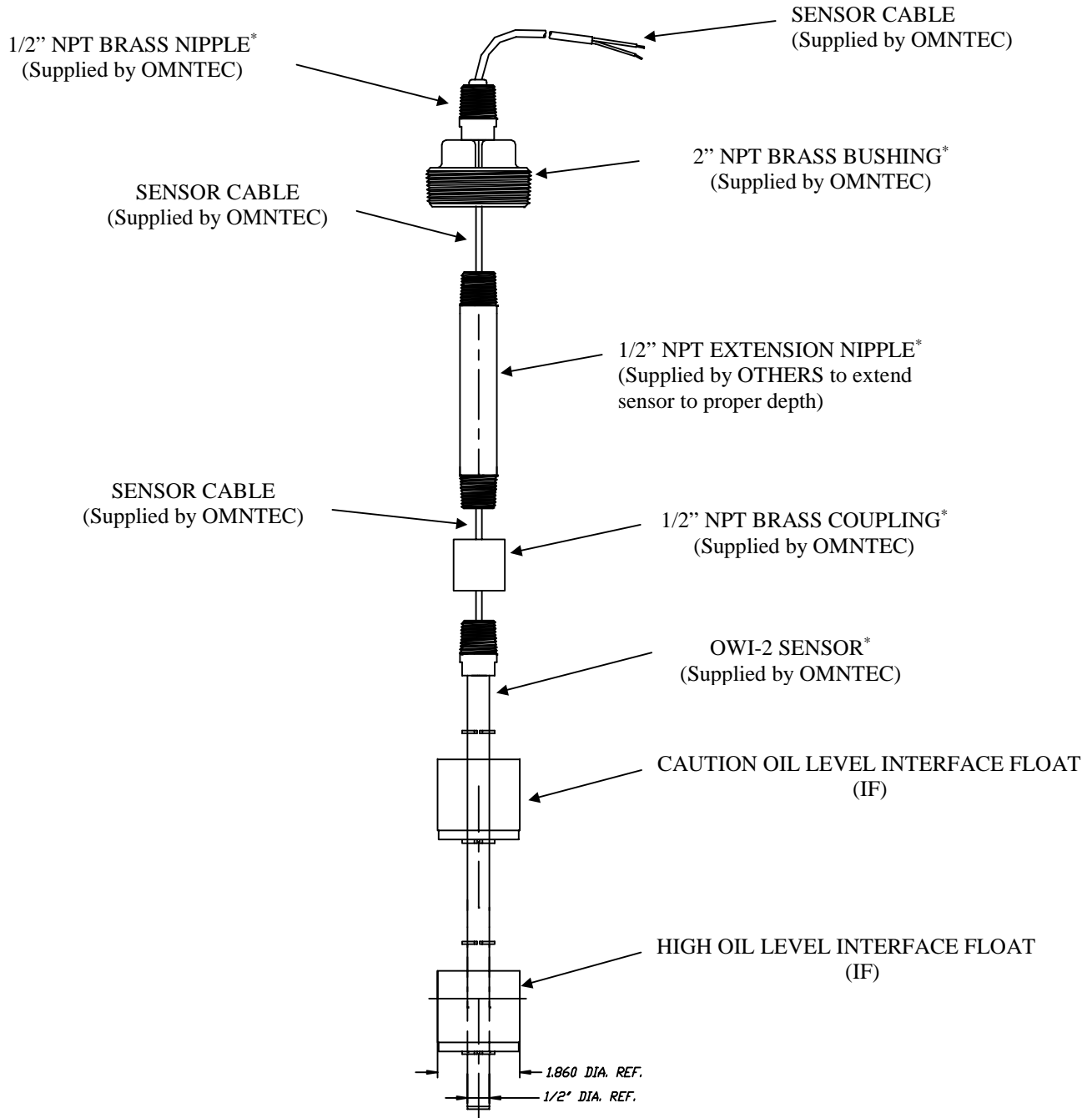

\* **WARNING-** It is the installer's responsibility to select a thread sealant that is compatible with the product being stored and that all NPT fittings are fastened properly to assure liquid tight seal for proper sensor operation.

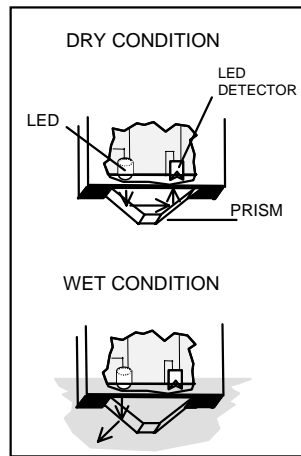
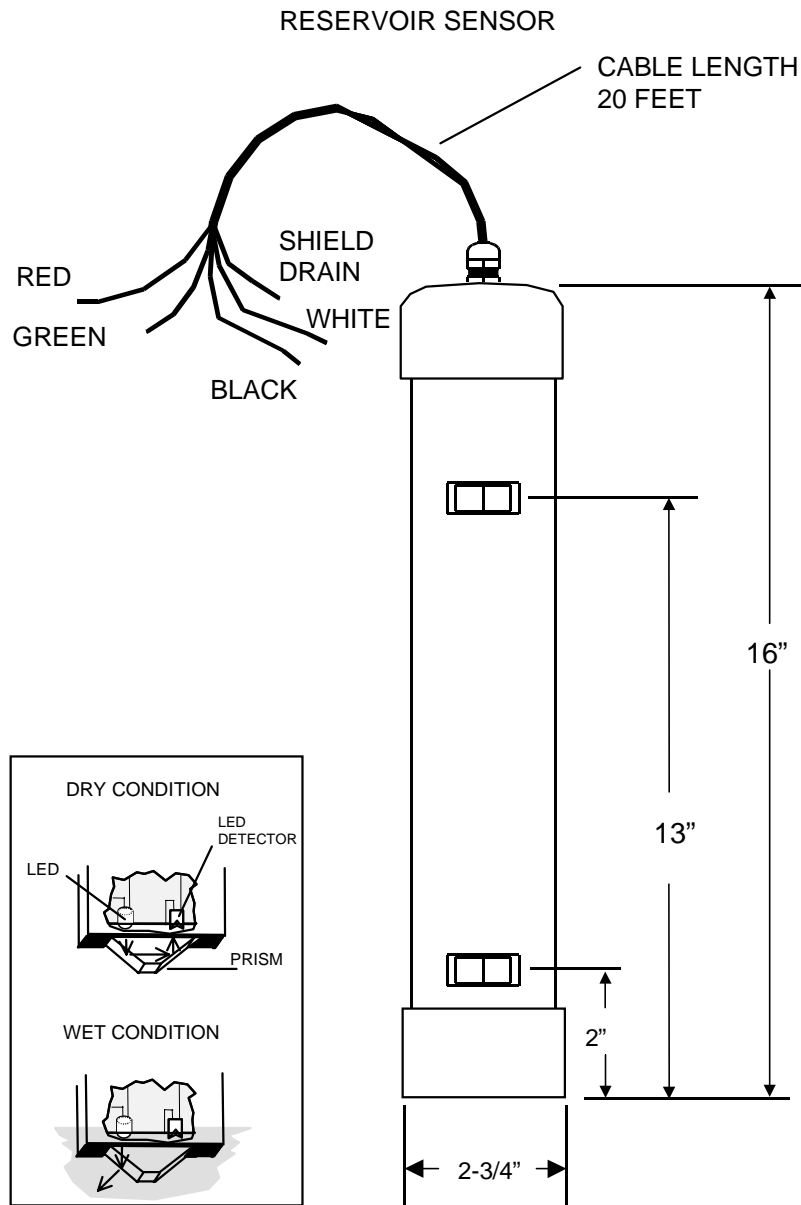

**SPECIFICATIONS**

SOLID STATE (NO MOVING PARTS)

|   |  |  |
|---|--|--|
| <p><b>RESPONSE TIME</b><br/>IMMEDIATE</p> | <p><b>SENSOR CABLE</b><br/>EC-4 OR BELDEN 9940<br/>MAXIMUM LENGTH 2000 FEET</p>          | <p><b>PRINCIPLES OF OPERATION</b><br/>NON POLAR LIQUIDS (FUEL OIL) - PHOTO OPTIC</p> <p>DRY CONDITION – HIGH LEVEL    NORMALLY CLOSED LIGHT BEAM<br/>ALARM CONDITION – CLOSED BEAM OF LIGHT OPENS (REFRACTS)<br/>NORMAL CONDITION-LOW LEVEL<br/>NORMALLY OPEN LIGHT BEAM<br/>ALARM CONDITION – OPEN BEAM OF LIGHT CLOSES</p> |
| <p><b>POWER</b><br/>2 VDC @ 13 mA</p>     | <p><b>OPERATING TEMPERATURE</b><br/>-40° to 140° F</p> <p><b>WEIGHT</b><br/>2 POUNDS</p> |  |

# L-R-1

## TYPICAL RESERVOIR SENSOR INSTALLATION

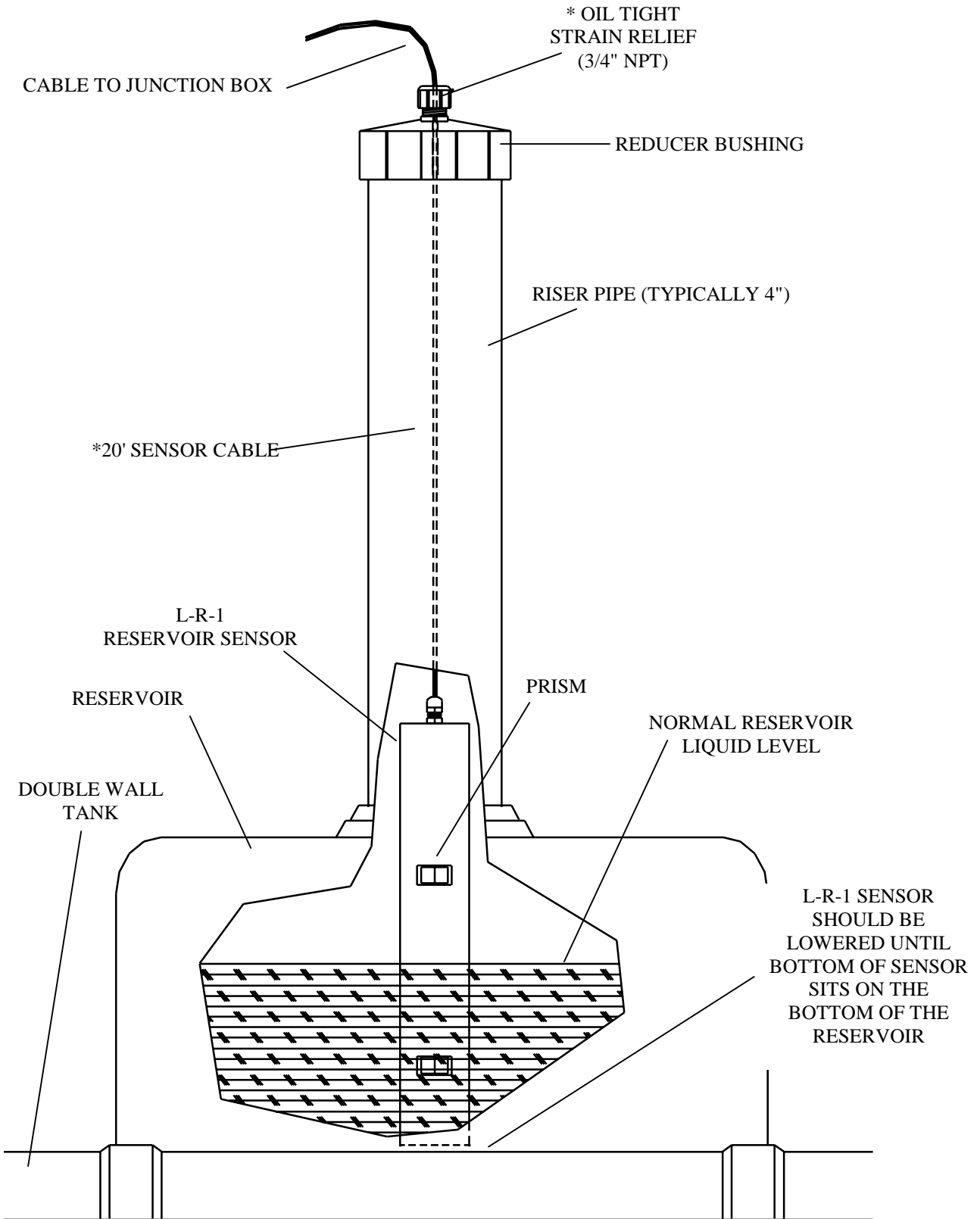

\*SUPPLIED BY OMNTEC/ELECTRO LEVELS MFG., INC.

Product distinguishing Optic Sensor

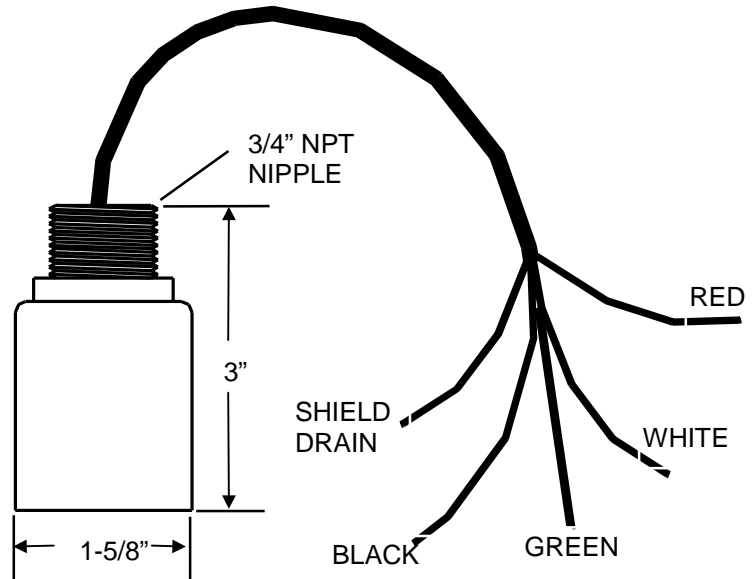
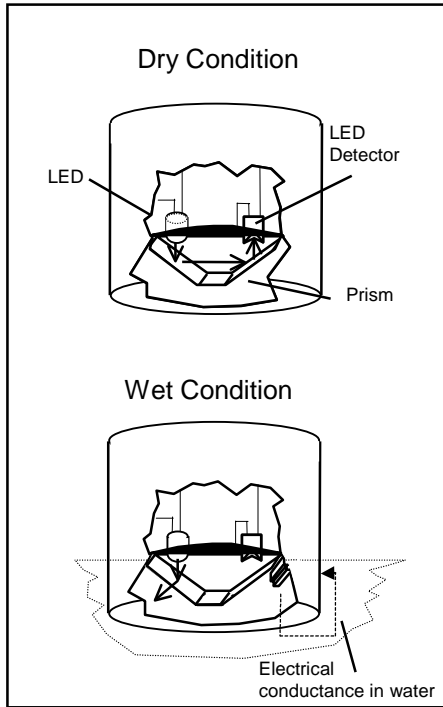

**SPECIFICATIONS**

Solid State (No moving parts)

**U.L. LISTED 5L04**

Intrinsically safe Class I, Group D Hazardous Locations when connected in accordance with Control Drawing nos. L1PD2, L2PD4, L3PD6

**OPERATING TEMPERATURE**

-40 TO +140 F

**POWER**

2 VDC @ 13 mA

**WEIGHT**

1/2 pound

**PRINCIPLES OF OPERATION**

WATER DETECTION - conductance  
 NON-POLAR LIQUIDS (ex: fuel) – Photo Optic  
 DRY CONDITION – Normally closed light beam  
 ALARM CONDITION – Opens (refracts) normally closed light beam

**SENSOR CABLE**

Shielded 22 AWG UL-E118830 CM  
 Maximum length 2000 feet

**RESPONSE TIME**

Immediate



## WARRANTY

---

The seller OMNTEC Mfg., Inc. warrants to buyer, for one year: That all components meet specifications herein. All components are free of defects when properly installed, and maintained by user. The sellers sole obligation is to repair or replace parts found to be defective, or non-conforming after evaluation by factory. The liability of the seller shall not exceed the price paid for the components found to be defective. The above warranty is exclusive of all other warranties whether implied or expressed. Seller assumes no obligation for special or, indirect damages incurred by user.